

R series 8800-11000lb forklift specification

NO.		Manufacture		E-P							
General	1	Basic model		CPQD40	CPQD40	CPQD45	CPQD45	CPQD50	CPQD50		
	2	Type		RW19	RW17-Y	RW19	RW17-Y	RXW19	RXW17-Y		
	3	Power type		Diesel	LPG	Diesel	LPG	Diesel	LPG		
	4	Rated capacity	lb	8800	8800	9900	9900	11000	11000		
	5	Load center	inch	20	20	20	20	20	20		
Dimensions	6	Lift height	inch	118	118	118	118	118	118		
	7	Free lift height	inch	6.3	6.3	6.3	6.3	6.3	6.3		
	8	Fork size	L×W×T	inch	67×6×2	67×6×2	67×6×2	67×6×2	67×6×2.2	67×6×2.2	
	9	Mast tilt range	F/R	deg	6/12	6/12	6/12	6/12	6/12	6/12	
	10	Fork overhang(Wheel center to fork face)	inch	21.7	21.7	21.7	21.7	21.9	21.7		
	11	Rear overhang	inch	20.5	20.5	22.0	22.0	22.0	22.0		
	12	Overall dimensions	Length to face of fork	inch	121	121	122	122	127	127	
	13		Overall width	inch	54.9	54.9	58.7	58.7	58.7	58.7	
	14		Mast lowered height	inch	88.4	88.4	88.4	88.4	94.3	94.3	
	15		Mast extended height	inch	164.2	164.4	164.2	164.2	170	170	
16	Overhead guard height	inch	88.6	88.6	88.6	88.6	88.6	88.6			
17	Turning radius(outside)	inch	106	106	107	107	111	111			
18	"Min. right angle stacking aisle width (Add load length and clearance)"	inch	128	128	129	129	132	132			
Performance	19	Speed	Travel(no load)	mile/h	16.1	16.1	16.1	16.1	16.1		
	Lifting(Full load)		inch/sec	18.1	18.1	18.1	18.1	15.7	15.7		
	21	Lowering(Full load)	Lifting(Full load)	inch/sec	19.7	19.7	19.7	19.7	19.7		
	22		Max. Drawbar Pull(Full load)	N	35900	39300	35900	39300	35900	39300	
	23	Max. gradeability(Full load)	%	20	20	20	20	20	20		
Wheels&Tires	24	Tyres	Front		8.25-15-14PR	8.25-15-14PR	300-15-14PR	300-15-14PR	300-15-14PR	300-15-14PR	
	25		Rear		7.00-12-12PR	7.00-12-12PR	7.00-12-12PR	7.00-12-12PR	7.00-12-12PR	7.00-12-12PR	
	26	Tread	Front	inch	45.7	45.7	46.9	46.9	46.9	46.9	
	27		Rear	inch	44.5	44.5	44.5	44.5	44.5	44.5	
	28	Wheelbase	inch	78.7	78.7	78.7	78.7	82.7	78.7		
	29	Ground clearance	Lowest	inch	6.7	6.7	6.7	6.7	6.7	6.7	
30	Wheelbase center		inch	9.1	9.1	9.1	9.1	9.1	9.1		
Weight	31	Self weight	lb	13860	13860	14300	14300	13860	14520		
	32	Weight Distribution	Full load	Front/Rear	lb	9000/1300	9000/1300	9625/1375	9625/1375	10125/1475	10125/1475
	33		No load	Front/Rear	lb	2800/3500	2800/3500	2820/3680	2820/3680	2820/3780	2820/3780
Power&Transmission	34	Battery	Voltage/Capacity(20HR)	V/AH	24/70/20H	12/70/20H	24/70/20H	12/70/20H	24/70/20H	12/70/20H	
	35	Engine	Model		TD42	GM4.3L	TD42	GM4.3L	TD42	GM4.3L	
	36		Manufacture		NISSAN	GM	NISSAN	GM	NISSAN	GM	
	37		Rated output/r.p.m.	hp	85/2300	74/2300	85/2300	74/2301	85/2300	74/2302	
	38		Rated torque/r.p.m.	N·m	274.4/1600	301/1600	274.4/1600	301/1601	274.4/1600	301/1602	
	39		No. of cylinder		6	6	6	6	6	6	
	40		Bore×Stroke	inch	3.8×3.8	4×3.5	3.8×3.8	4×3.5	3.8×3.8	4×3.5	
	41		Displacement	cc	4169	4294	4169	4294	4169	4294	
	42		Fuel tank capacity	L	80	40	80	40	80	40	
	43		Manufacture		CHINA	CHINA	CHINA	CHINA	CHINA	CHINA	
	44		Transmissions	Type		Powershift	Powershift	Powershift	Powershift	Powershift	Powershift
	45			Stage	FWD/RVS	2/1	2/1	2/1	2/1	2/1	2/1
46	Operating pressure	For attachments	MPa	18	18	18	18	18	18		

1.Special lifting height available. 2.Attachment available.
 3.The specification in the table are for standard models only. For further information please contact us.
 4.Specification are subject to change without notice.

Customization is available
 Products and specifications are
 subject to be changed without notice

Optional Feature

- 2.0-5.0m/79-197inch duplex mast
- 2.5-5.0m/98-157inch full free duplex mast
- 4.3-6.5m/169-256inch triplex mast
- Special carriage and backrest
- Other dimension forks
- Dual drive wheel with fender
- Super elastic tyre
- Colored tyre (white, green)
- Cabin
- Heater and air condition
- Fire extinguisher
- Semi-suspension seat or full-suspension seat
- Dual air cleaner or special air cleaner
- Rear working light
- Custom color paint
- Auxiliary hydraulic valve modules
- High-mounted exhaust system
- Middle-mounted exhaust system
- Anti-fire spark exhaust device
- Diesel exhaust gas purifier
- 3-way catalytic muffler
- LPG swing-down bracket
- Radiator screen
- Sideshifter
- Integrated sideshifter
- Other attachment
- LPG fuel system (single, dual)



E-P Equipment Co.,LTD
 Let's grow together...

www.ep-ep.com
www.epforklift.com

China: (Headquarters)
 E-P EQUIPMENT CO., LTD
 No. 121 YongHua Street, Shi Qiao Road, Xia Cheng
 Qu Hangzhou, China
 Tel: 86-571-28035676/28035633/28035657/28035653
 Fax: 86-571-28035665
 Email: info@ep-ep.com

USA:
 E-P EQUIPMENT, USA CORP.
 1770 Campton Road
 Inmam, SC 29349
 Tel: 864-472-2776
 Fax: 864-472-2765
 E-mail: info@ep-ep.com

Japan:
 E-P EQUIPMENT JAPAN
 #1052-16-10 Hirao, Inagi-shi
 Tokyo 206-0823 Japan
 Tel: 81-42-3506422
 Fax: 81-42-3506423
 E-mail: ep-japan@ep-ep.com

Korea:
 E-P EQUIPMENT KOREA
 1058-Ra Dong, Buck Yi-Dong,
 Ilsan/Gu, Koyang/Shi, Kyunggi/
 Du, Korea
 Tel: 82-31-9254100
 Fax: 82-31-9254102
 E-mail: ep@ep-ep.co.kr



CE
 ISO9000

Rseries

4.0/4.5/5.0T
 8800/9900/11000lb
 Diesel/LPG



www.ep-ep.com
www.epforklift.com

R series 4.0-5.0t forklift specification

NO.		Manufacture									
General	1	Basic model		CPCD40	CPQD40	CPCD45	CPQD45	CPCD50	CPQD50		
	2	Type		RW19	RW17-Y	RW19	RW17-Y	RXW19	RXW17-Y		
	3	Power type		Diesel	LPG	Diesel	LPG	Diesel	LPG		
	4	Rated capacity		Kg	4000	4000	4500	4500	5000	5000	
	5	Load center		mm	500	500	500	500	500	500	
Dimensions	6	Lift height		mm	3000	3000	3000	3000	3000	3000	
	7	Free lift height		mm	160	160	160	160	160	160	
	8	Fork size	LxWxT	mm	1700x150x50	1700x150x50	1700x150x50	1700x150x50	1700x150x55	1700x150x55	
	9	Mast tilt range		deg	6/12	6/12	6/12	6/12	6/12	6/12	
	10	Fork overhang(Wheel center to fork face)		mm	550	550	550	550	555	550	
	11	Rear overhang		mm	520	520	560	560	560	560	
	12	Overall dimensions	Length to face of fork		mm	3070	3070	3110	3110	3215	3215
	13		Overall width		mm	1395	1395	1490	1490	1490	1490
	14		Mast lowered height		mm	2245	2245	2245	2245	2395	2395
	15		Mast extended height		mm	4170	4175	4170	4170	4320	4320
	16	Overhead guard height		mm	2250	2250	2250	2250	2250	2250	
	17	Turning radius(outside)		mm	2690	2690	2720	2720	2810	2810	
	18	*Min. right angle stacking aisle width (Add load length and clearance)*		mm	3240	3240	3270	3270	3360	3360	
Performance	19	Travel(no load)		Km/h	26	26	26	26	26	26	
	20	Speed	Lifting(Full load)	mm/sec	460	460	460	460	400	400	
	21		Lowering(Full load)	mm/sec	500	500	500	500	500	500	
	22	Max. Drawbar Pull(Full load)		N	35900	39300	35900	35900	35900	35900	
	23	Max. gradeability(Full load)		%	20	20	20	20	20	20	
Wheels&tires	24	Tyres	Front		8.25-15-14PR	8.25-15-14PR	300-15-14PR	300-15-14PR	300-15-14PR	300-15-14PR	
	25		Rear		7.00-12-12PR	7.00-12-12PR	7.00-12-12PR	7.00-12-12PR	7.00-12-12PR	7.00-12-12PR	
	26	Tread	Front	mm	1160	1160	1190	1190	1190	1190	
	27		Rear	mm	1130	1130	1130	1130	1130	1130	
	28	Wheelbase		mm	2000	2000	2000	2000	2100	2100	
	29	Ground clearance	Lowest	mm	170	170	170	170	170	170	
30	Wheelbase center		mm	230	230	230	230	230	230		
Weight	31	Self weight		Kg	6300	6300	6500	6500	6300	6600	
	32	Weight Distribution	Full load	Front/Rear	kg	9000/1300	9000/1300	9625/1375	9625/1375	10125/1475	10125/1475
	33		No load	Front/Rear	kg	2800/3500	2800/3500	2820/3680	2820/3680	2820/3780	2820/3780
Power&transmission	34	Battery		V/AH	24/70/20H	12/70/20H	24/70/20H	12/70/20H	24/70/20H	12/70/20H	
	35	Model			TD42	GM4.3L	TD42	GM4.3L	TD42	GM4.3L	
	36	Manufacture			NISSAN	GM	NISSAN	GM	NISSAN	GM	
	37	Rated output/r.p.m.		kw	62.5/2300	74/2300	62.5/2300	74/2301	62.5/2300	74/2302	
	38	Rated torque/r.p.m.		N*m	274.4/1600	301/1600	274.4/1600	301/1601	274.4/1600	301/1602	
	39	No. of cylinder			6	6	6	6	6	6	
	40	BorexStroke		mm	96x96	102x88	96x96	102x88	96x96	102x88	
	41	Displacement		cc	4169	4294	4169	4294	4169	4294	
	42	Fuel tank capacity		L	80	40	80	40	80	40	
	43	Manufacture			CHINA	CHINA	CHINA	CHINA	CHINA	CHINA	
	44	Transmissions		Type	Powershift	Powershift	Powershift	Powershift	Powershift	Powershift	
	45			Stage	FWD/RVS		2/1	2/1	2/1	2/1	
	46	Operating pressure		For attachments	MPa	18	18	18	18	18	18

1.Special lifting height available . 2.Attachment available.
 3.The specification in the table are for standard models only. For further information please contact us .
 4.Specification are subject to change without notice.

R series 4.0-5.0t forklift mast :(pneumatic)

Type	Model	Mast fork height	Overall height								Free lift				Tilt range		Capacity					
			Lowered		Extended without backrest		Extended with backrest		Without backrest		With backrest		Front Overhang				Load capacity at 500 mm					
			4/4.5t	5t	4/4.5t	5t	4/4.5t	5t	4/4.5t	5t	4/4.5t	5t	4/4.5t	5t	FWD	RWD	Single tire			Double tire		
			mm	mm	mm	mm	mm	mm	mm	mm	mm	mm	mm	mm	Deg	Deg	Kg	Kg	Kg	Kg	Kg	Kg
Wideview mast	R45/50M250	2500	1995	2145	3330	3495	3670	3820	160	160	160	160	550	555	6	12	4000	4500	5000	4000	4500	5000
	R45/50M270	2700	2095	2245	3530	3695	3870	4020	160	160	160	160	550	555	6	12	4000	4500	5000	4000	4500	5000
	R45/50M300	3000	2245	2395	3830	3995	4170	4320	160	160	160	160	550	555	6	12	4000	4500	5000	4000	4500	5000
	R45/50M330	3300	2395	2545	4130	4295	4470	4620	160	160	160	160	550	555	6	12	4000	4500	5000	4000	4500	5000
	R45/50M350	3500	2495	2645	4330	4495	4670	4820	160	160	160	160	550	555	6	12	4000	4500	5000	4000	4500	5000
	R45/50M360	3600	2545	2695	4430	4595	4770	4920	160	160	160	160	550	555	6	12	4000	4500	5000	4000	4500	5000
	R45/50M400	4000	2795	2895	4830	4995	5170	5320	160	160	160	160	550	555	6	12	3800	4250	4750	4000	4500	5000
	R45/50M430	4300	2960	3045	5130	5295	5470	5620	160	160	160	160	550	555	6	6	3600	4000	4500	3800	4250	4750
	R45/50M450	4500	3070	3145	5330	5495	5670	5820	160	160	160	160	550	555	6	6	3400	3800	4250	3600	4050	4500
	R45/50M480	4800	3235	3295	5630	5795	5970	6120	160	160	160	160	550	555	6	6	3200	3350	3750	3200	3600	4000
Wide view full free 2-stage mast	R45/50M500	5000	3345	3395	5830	5995	6170	6320	160	160	160	160	550	555	6	6	3000	3150	3500	3000	3400	3750
	R45/50U300	3000	2225	2375	3870	4035	4168	4318	1365	1365	1055	1055	565	570	6	12	4000	4500	5000	4000	4500	5000
	R45/50U330	3300	2375	2525	4170	4335	4468	4618	1500	1500	1205	1205	565	570	6	12	4000	4500	5000	4000	4500	5000
Wide view full free 3-stage mast	R45/50N430	4300	2205	2305	5205	5355	5490	5640	1325	1275	1034	840	603	615	6	6	3400	3800	4250	3600	4050	4500
	R45/50N450	4500	2270	2370	5400	5550	5690	5840	1390	1340	1100	910	603	615	6	6	3200	3600	4000	3400	3850	4250
	R45/50N480	4800	2365	2465	5700	5850	5990	6140	1485	1435	1195	1005	603	615	6	6	3000	3350	3750	3200	3600	4000
	R45/50N500	5000	2435	2535	5900	6050	6190	6340	1555	1505	1264	1070	603	615	6	6	2800	3150	3500	3000	3300	3750
	R45/50N550	5500	2600	2700	6400	6550	6690	6840	1720	1670	1430	1240	603	615	3	6	2250	2550	2850	2800	3000	3350
	R45/50N600	6000	2815	2915	6945	7095	7190	7340	1935	1885	1644	1450	603	615	3	6	1700	1950	2200	2600	2800	2950

DIMENSIONS

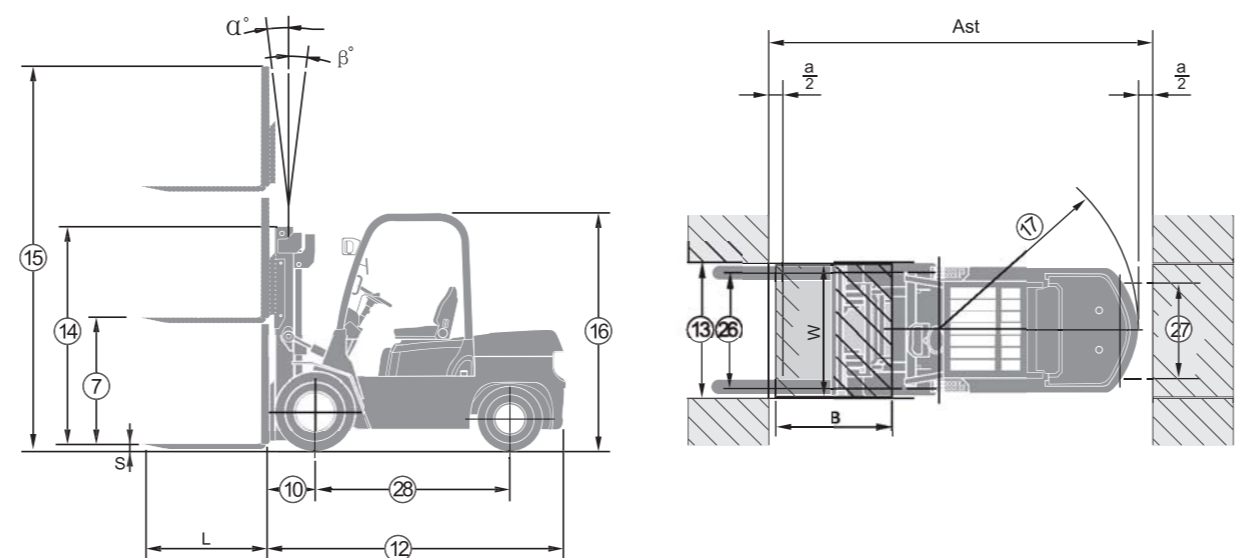

R series 8800-11000lb forklift mast :(pneumatic)

Type	Model	Mast fork height	Overall height								Free lift				Tilt range		Capacity					
			Lowered		Extended without backrest		Extended with backrest		Without backrest		With backrest		Front Overhang				Load capacity at 20 inch					
			8800/9900lb	11000lb	8800/9900lb	11000lb	8800/9900lb	11000lb	8800/9900lb	11000lb	8800/9900lb	11000lb	8800/9900lb	11000lb	FWD	RWD	Single tire			Double tire		
			inch	inch	inch	inch	inch	inch	inch	inch	inch	inch	inch	inch	Deg	Deg	lb	lb	lb	lb	lb	lb
Wideview mast	R45/50M250	98	79	84	131	138	144	150	6.3	6.3	6.3	6.3	21.7	21.9	6	12	8800	9900	11000	8800	9900	11000
	R45/50M270	106	82	88	139	145	152	158	6.3	6.3	6.3	6.3	21.7	21.9	6	12	8800	9900	11000	8800	9900	11000
	R45/50M300	118	88	94	151	157	164	170	6.3	6.3	6.3	6.3	21.7	21.9	6	12	8800	9900	11000	8800	9900	11000
	R45/50M330	130	94	100	163	169	176	182	6.3	6.3	6.3	6.3	21.7	21.9	6	12	8800	9900	11000	8800	9900	11000
	R45/50M350	138	98	104	170	177	184	190	6.3	6.3	6.3	6.3	21.7	21.9	6	12	8800	9900	11000	8800	9900	11000
	R45/50M360	142	100	106	174	181	188	194	6.3	6.3	6.3	6.3	21.7	21.9	6	12	8800	9900	11000	8800	9900	11000
	R45/50M400	157	110	114	190	197	204	209	6.3	6.3	6.3	6.3	21.7	21.9	6	12	8360	9350	10450	8800	9900	11000
	R45/50M430	169	117	120																		